

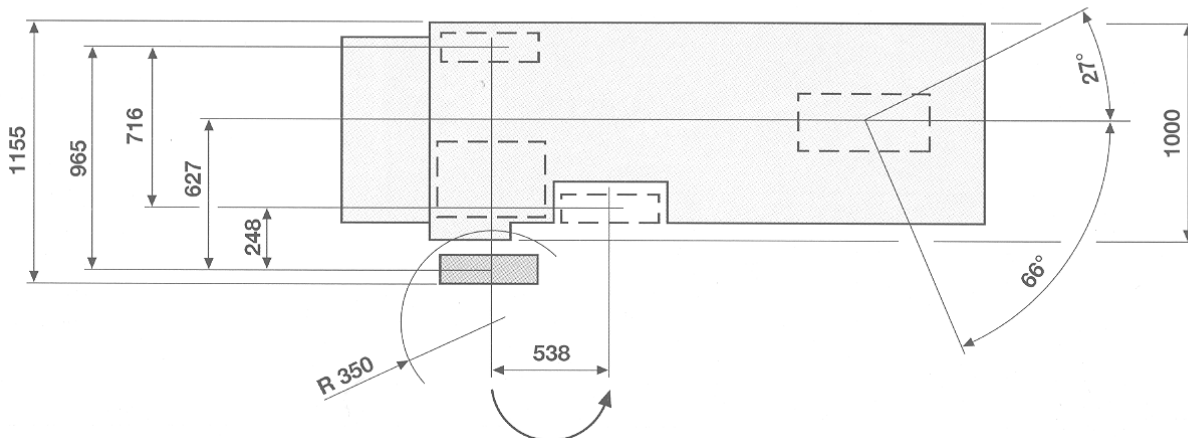

KALTFRÄSE W 350 E

Masse in mm

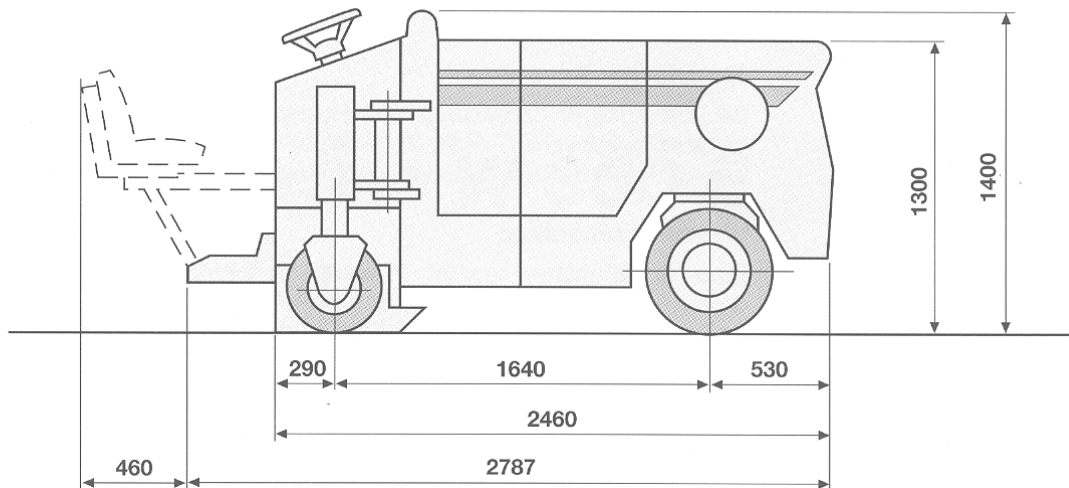

Technische Daten		Komplett	Ohne Zusatzgewichte	Demarkierung/ Feinfräswalze	Schneidräder	
Fräsbreite	mm	350		250 / 350	14	60
Frästiefe	mm	0 – 100		15	0 - 100	0 – 160
Elektrische Angaben:						
Spannung	V	380 - 400				
Voll-Laststrom	A	63				
Schutzart		IP 55				
Gewichte						
Achslast vorne	kg	2.325	1.625			
Achslast hinten	kg	2.175	1.525			
Eigengewicht	kg	4.100	2.800			
Betriebsgewicht	kg	4.500	3.150			