

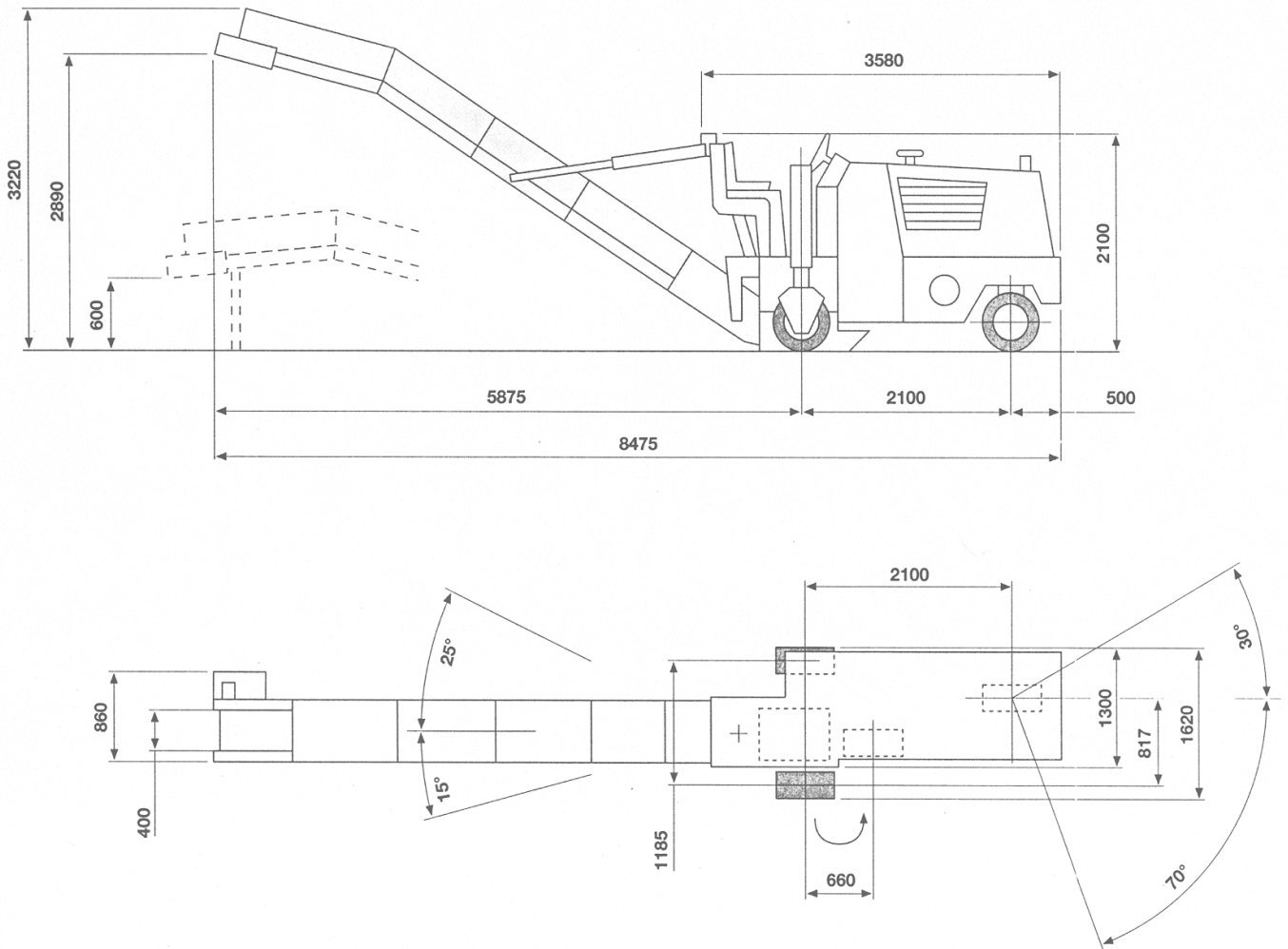

# KALTFRÄSE W 500

Masse in mm



Technische Daten		W 500 mit	W 500 ohne	Schneidräder	
		Ladeband	Ladeband	14	80
Fräsbreite	mm	500	500	14	80
Frästiefe	mm	0 - 160	0 - 160	0 - 140	0 - 220
<b>Füllmengen</b>					
Kraftstofftank	l	165			
Hydrauliköltank	l	150			
Wassertank	l	230			
<b>Gewichte</b>					
Achslast vorne	kg	2'200	2'800		
Achslast hinten	kg	4'600	3'200		
Eigengewicht	kg	6'800	6'000		
Betriebsgewicht	kg	7'400	6'600		