

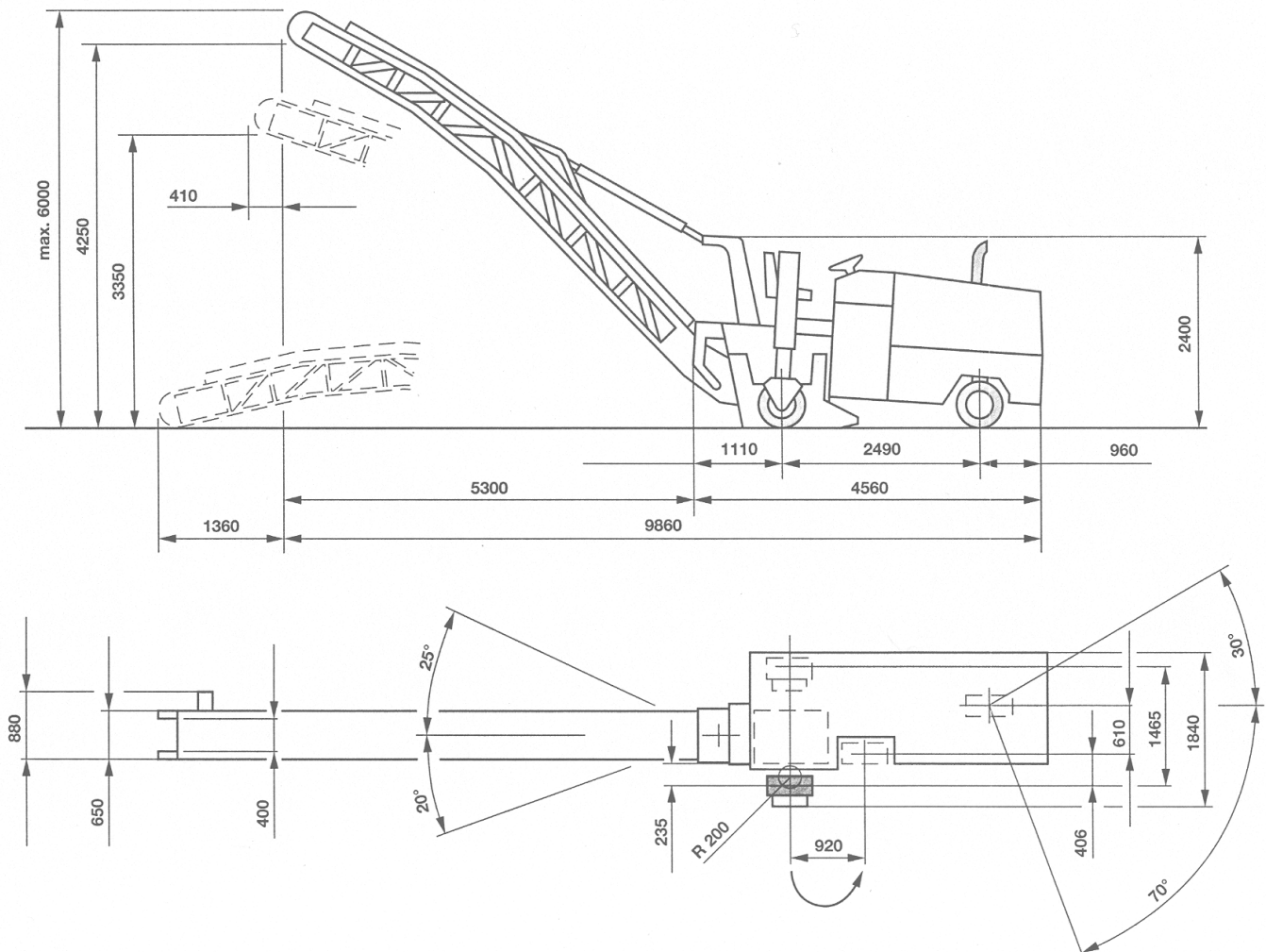

KALTFRÄSE W 600 DC

Masse in mm



Technische Daten		Mit Ladeband	Ohne Ladeband	Spezialwalze	Schneidrad	
Fräsbreite	mm	600	600	400 / 500	80	80
Frästiefe	mm	0 - 300	0 - 300	0 - 300	0 - 250	0 - 300
Füllmengen						
Kraftstofftank	l	250				
Hydrauliköltank	l	75				
Wassertank	l	425				
Gewichte						
Achslast vorne	kg	4'750	5'350			
Achslast hinten	kg	7'850	5'850			
Eigengewicht	kg	12'000	11'200			
Betriebsgewicht	kg	12'600	11'800			